

**SAB Drum Service Brake – AISE N. 11-63 120**

**SAB brakes**

According to standard AISE N. 11 - 63.120

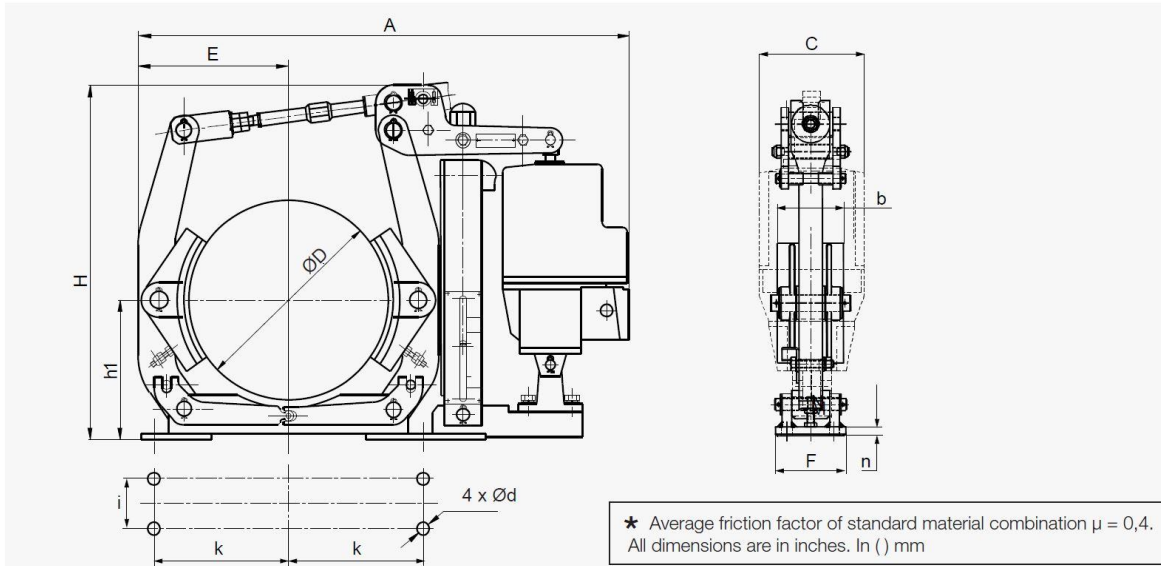

Brake type	Thrustor TS	M <sub>BR MAX</sub> (lb-ft) *	A	b	C	D	d	E	F	H	h1	i	k	n	Weight (lb)
SAB - 6"	230/5	55-110	17	1.65	6.3	6 (152)	3/8 (9.5)	5.5	7.25	16.5	4.75 (120)	3 (76)	4 (102)	0.38	70
SAB - 8"	230/5	85-190	26.00	3.00	6.3	8 (203)	0.69 (17)	6.77	7.25	20	7.0 (178)	5.76 (146)	3.25 (83)	0.31	77
	300/5	140-275													84
SAB - 10"	230/5	110-220	30.30	3.54	6.3	10 (254)	0.69 (17)	7.95	8.00	23.2	8.38 (213)	6.26 (160)	4.0 (102)	0.60	100
	300/5	140-280													106
	500/6	220-440													116
SAB - 12"	300/5	170-345	37.00	5.51	6.3	12 (305)	0.81 (21)	10.40	11.00	23.4	9.88 (251)	9.0 (228)	5.75 (146)	0.60	155
	500/6	270-540													164
	800/6	430-855													176
SAB - 13"	300/5	180-375	37.00	5.51	6.3	13 (330)	0.81 (21)	10.40	11.00	23.4	9.88 (251)	9.0 (228)	5.75 (146)	0.60	160
	500/6	295-590													164
	800/6	460-930													176
SAB - 15"	500/6	330-665	40.20	6.49	6.3	15 (381)	1.06 (27)	12.20	13.25	28.4	12.13 (308)	10.76 (273)	7.5 (191)	0.60	300
	800/6	515-1030													308
	1210/6	840-1675													335
SAB - 16"	500/6	355-710	40.20	6.49	7.7	16 (406)	1.06 (27)	12.20	13.25	28.4	12.13 (308)	10.76 (273)	7.5 (191)	0.60	304
	800/6	550-1110													308
	1210/6	900-1800													335
SAB - 19"	800/6	665-1330	49.00	8.50	7.7	19 (483)	1.06 (27)	15.00	16.20	31.9	13.25 (337)	13 (330)	9.25 (235)	0.79	445
	1210/6	1055-2110													455
	2010/6	1700-3390													455
SAB - 23"	1210/6	1220-2440	63.40	10.98	9.45	23 (584)	1.31 (33)	17.50	18.75	41.0	15.88 (403)	16 (406)	11.75 (298)	0.79	695
	2010/6	1900-3870													695
	3010/6	2850-5760													705
	3010/12	3450-6900													
SAB - 30"	1210/6	1400-2800	68.00	14.01	9.45	30 (762)	1.56 (40)	21.50	23.00	44.5	20.75 (527)	19 (482)	15.0 (381)	1.18	950
	2010/6	2360-4720													950
	3010/6	3650-7370													980
	3010/12	4400-8800													