

Storm Brakes

HWB-Hydraulic Wheel Brake Dynamic Spring Set, Hydraulic Release shown

STANDARD FEATURES

- Fabricated from high quality structural steel.
- Brake shoes easily removed and replaced
- Min Paint Thickness DFT: 200-275 µm

SUPPLIED WITH BRELX HPU HYDRAULIC POWER UNIT

- Prewired junction box
- Hand pump for manual release
- Solenoid valve with manual override
- Solenoid coil with LED indicator

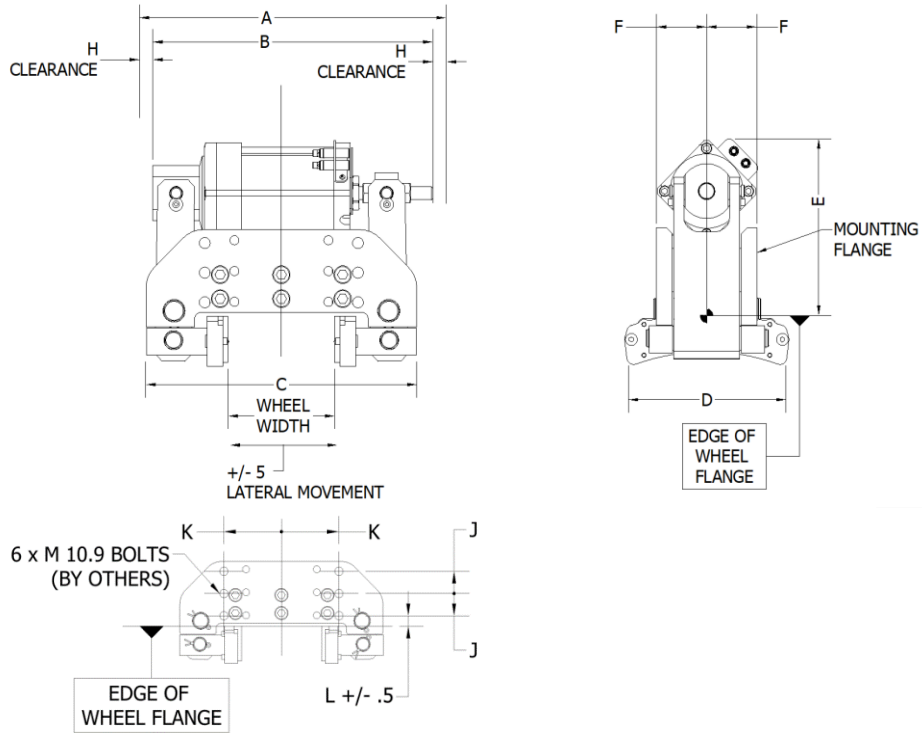

MODEL	HOLDING CAPACITY (kN)	A	B	C	D	E	F	H	J	K	L	M
HWB-30-A	30	600	535	500	315	330	75	30	50	125	25	M20
HWB-30-B									57	89	26	M20
HWB-60-A	60	600	535	500	315	330	75	30	50	125	25	M20
HWB-60-B									57	89	26	M20
HWB-90-A	90	600	535	550	315	330	110	30	55	145	30	M24
HWB-90-B									57	89	26	M20
HWB-120-A	120	600	535	550	315	330	110	30	55	145	30	M24
HWB-120-B									57	89	26	M20

Dynamic models braking capacities calculated with coefficient of friction factor 0.4

All dimensions (mm) and capacities (kN) subject to change without notification.